

MIXER AND CONE PASTE 1.200 KG

FULLY AUTOMATIC PASTE MIXER AND RELIABLE ADDITIVES WEIGHING AND ADDITION



The following parts compose it:

Paste tank.

Cylindrical steel tank to contain the paste. The tank inside part is turned and thermally stretched. The tank is closed in the upper part with a stainless steel AISI 304 lid, where there are the inspection doors, the tube for cooling air inlet and outlet, the tubes for the inlet of acid and water, the lead inlet coming from the dosing silo.

The paste mixed and ready to be paste is extracted using the door in the front part of the tank.

Mixing system

The rotating paddles produce a complete mixing action of the various components (lead,

acid, water and additives) to obtain a uniform and easily pasting paste.

The mixer is equipped with scraping paddles, which clean perfectly the inside of the mixer.

Cooling system .

In the mixing cycle is essential the temperature produced by the exothermic reaction developed between the H₂SO₄ and the lead oxide. The temperature is maintained to the values fixed using the two cooling systems assuring a good quality of paste preparation. The first cooling system by means of a fan blows the paste surface cooling it, the second one by means of circulating water maintains the bottom of tank cool. The air comes directly inside the vacuum fan system connected with the air depuration system. (scrubber). The machine vacuum-operated avoids dust and steams exit in case of inspection doors opening.

Operation

The necessary quantity of lead oxide for the paste preparation is unloaded from the dosing lead silo to the mixer. The paddles turns and afterwards are introduced water, acid and additives following the cycle times foresee. The sulphuric acid inlet provokes an exothermic reactions, which develops heat, that rises the temperature of the paste preparation more than the acceptable values (58%). The cooling system lowers the paste preparation temperature under the maximum ones. This aim is reached maintaining the room under pressure (100 ÷ 110 mm H₂O) with this depression values the water evaporation take

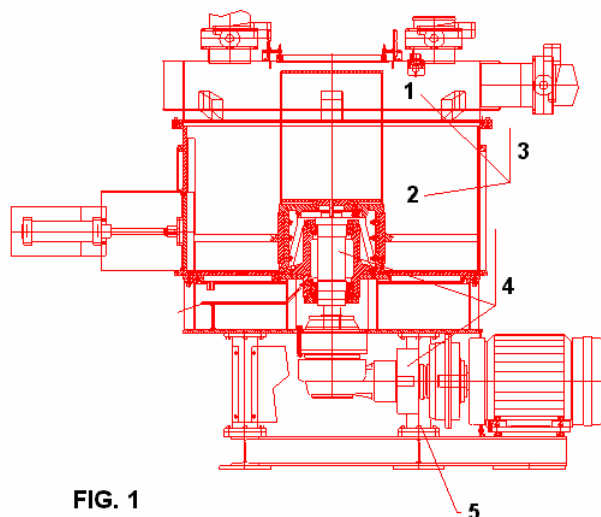

FIG. 1

place at ca. 50 ÷ 55°C. Taking advantage of this physical principle we block the paste temperature rise. The special paddles shape produces a complete mixing action, which lifts the oxide from the bottom of the tub to the top of the mix for a more uniform mix. At the end of the mixing the PLC, that controls all the process, let open the door and the paste comes out from the outlet openings. The mixer is positioned at certain high from the stairs, if the cycle is completely automatic, and the paste is collected by a rotating cone. It slides on guides, which takes the paste on the pasting hopper. CBE srl is able to supply the complete automatic plant namely: lead silo, support frame for mixer, lead-dosing silo, load and unload water and acid automatic system, mixer, paste cone and electric control panel.

Technical data of the machine.

Dimensions: Length 3300 mm Height 2500 mm Width 2000 mm 380 V, 50 Hz (three-phase)

Installed power: 45 kW

Fan motor power: 1,5 kW

Air pressure : 6 Bar

Extraction air capacity: 2500 m³/h

Water capacity : 0,4 m³/h

Cycle time: 30 min

One cycle production : 1200 Kg paste

PASTE DISTRIBUTION CONE

The paste distribution cone enables to collect the paste coming from the mixer and unload it in the pasting hopper.

Paste cone.

The cone containing the paste is made of thermally flatten steel to eliminate the tensions of the previous works. A fifth wheeler supports the cone enabling a complete turn of the cone by means of a gear motor, this system facilitates the paste ejection at the paste discharge moment in the paste hopper. A blade inside the cone removes the paste from the cone sides during his rotation and let it fall down in the pasting hopper.

The cone has an automatic opening/closing system, which enables the ejection of the paste at the discharge moment.

Cone support system: A welded steel framework supports the cone. A gear motor fixed on the structure transmits the rotation movement to the cone. The system slides on lines, which guides the cone from the mixer up to the pasting machine.

Technical data:

Electricity : 380 V, 50 Hz (three-phases)

Dimensions : Length 1500 mm, height 1600 mm, Width 1400 mm

Installed power : 6,2 kW

Total cone capacity : 2600 Kg paste

